

Todd Gas Caddy

WARNINGS AND INSTRUCTIONS FOR GASOLINE USE

**PLEASE READ ALL OF THIS INFORMATION
DANGER – EXTREMELY FLAMMABLE
VAPORS CAN EXPLODE
HARMFUL OR FATAL IF SWALLOWED**

**FILL AND TRANSPORT CONTAINER
IN HORIZONTAL POSITION ONLY**

- ! Vapors can cause flash fire.
- ! Vapors can be ignited explosively by a spark or flame many feet away.
- ! Use and store in a well ventilated location.
- ! **DO NOT** store indoors or in vehicle.
- ! Keep away from flames, sparks, pilot lights, stoves, heaters, electric motors or other sources of ignition.
- ! **DO NOT** smoke near gas tank.
- ! **DO NOT** siphon gas by mouth.
- ! Avoid repeated or prolonged contact with skin or breathing of gas vapors.
- ! If swallowed, **DO NOT** induce vomiting. Call physician immediately.
- ! Keep out of reach of children.
- ! Fill cap, dispensing valve and outlet valve must be closed tightly after each use.
- ! **DO NOT** overfill container.
- ! **DO NOT** Fill in the back of a pickup truck or any vehicle.
- ! **Maximum Capacity: 28 U.S. gallons**

Todd Gas Caddy Assembly Instructions

Parts list: Gas Caddy, (2) handles, (2) pneumatic tires, (1) 5/8" dia. axle, (6) 5/8" stainless washers, (2) plastic spacers, (2) Pal nuts, (4) Phillips Head screws 1 1/2" long with washers, (2) hose brackets with four 1/4" machine screws and (4) 1/4" washers.

Tools required: Phillips head screwdriver, hammer and supplied block of wood.

Assembly Instructions:

1. Place the Gas Caddy face down and position the handles in the handle grooves with the curved ends at the top pointing up.
2. Slide the axle through the handles.
3. Insert the 4 Phillips Head screws with washers through the holes in the handles and loosely attach the handles

Drawing 1

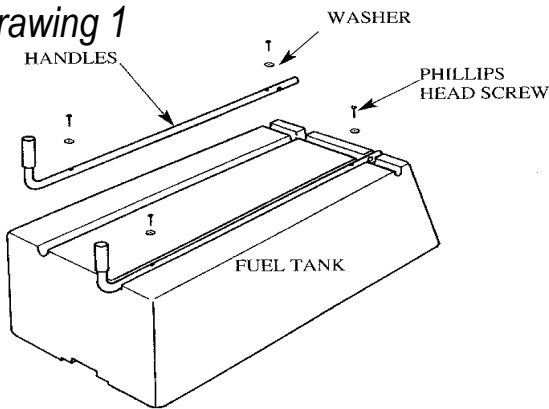

4. On each end of the axle, in this order, place a washer, spacer, washer, tire, washer and Pal nut. (See *Drawing 2*.) To seat the Pal nut correctly, place the nut on the axle and tap it with a hammer until the axle reaches the full depth of the nut. (See *Drawing 3*.)

(Note: For best results, before putting on Pal nut, place wood block on floor lay Caddy on its side with end of axle placed on top of wood perpendicular to the floor.)

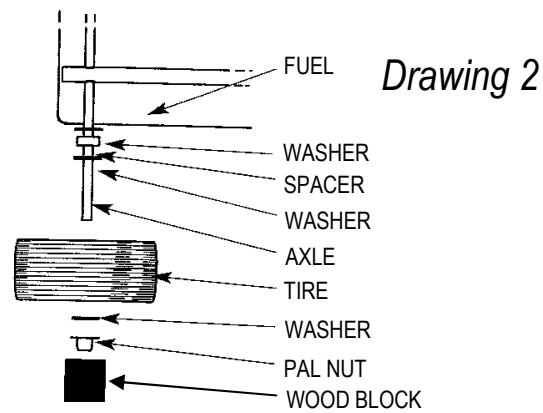
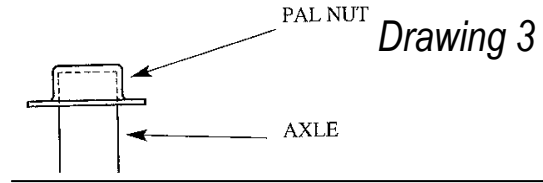

5. Tighten the 4 Phillips Head screws holding the handles to the tank securely.

6. Hose Bracket installation: Using two of the 1/4" machine screws and washers attach the bottom bracket to the caddy. Note the bottom bracket has a hole for holding the nozzle. With the remaining screws and washers attach the top bracket. Tighten the screws securely. (See *Drawing 4*.)

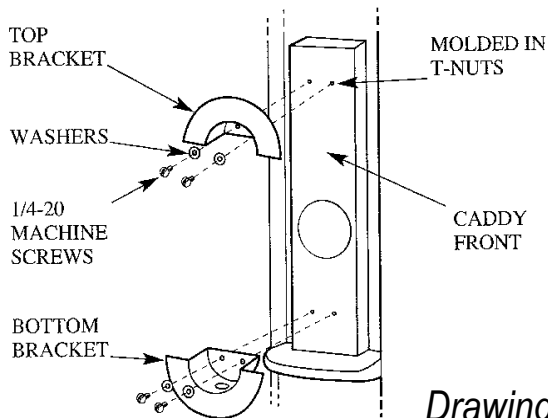

Drawing 4

Todd Gas Caddy Filling Instructions

1. Fill the Gas Caddy in a horizontal position only. Do not fill in or on a motor vehicle or marine craft.
2. Remove vented fill cap.
3. Check to see that the ball valve is in the *closed* position.
4. Discharge your static electricity before fueling by physically touching a metal surface away from the nozzle.
5. Fill tank slowly to decrease chance of static electricity buildup.
Caution: Do not over fill tank.
28 U.S. gallon maximum capacity.
6. Replace fill cap and check that the vent is closed.

IMPORTANT: WHEN FILLING THE GAS CADDY, IT MUST BE IN A HORIZONTAL POSITION.

WARNING:

PRIOR TO TRANSFERRING FUEL, AND BEFORE OPENING THE FILL PORT OF THE RECEIVING TANK, ATTACH THE GROUNDING CLAMP TO THE GROUNDING POINT OF THE RECEIVING TANK, TO HELP PREVENT STATIC IGNITION.

Todd Gas Caddy Dispensing Instructions

Model 932403WP

When using rotary hand pump for fueling

1. Gas Caddy should be on the ground. Attach the grounding clamp to the grounding point of the receiving tank to help prevent static electricity ignition of fuel vapors.
2. Twist the fill cap vent screw one turn counter-clockwise. This allows the tank to vent and the fuel to flow smoothly.
3. Open ball valve.
4. Insert hose nozzle into tank to be filled, squeeze handle and crank pump.
5. When fuel transfer is complete, release the nozzle handle to stop fuel flow.
6. Close the ball valve.
7. Close the fill cap vent.

Safety Guidelines When Refueling

NOTE

Gasoline is a toxic, flammable and potentially dangerous substance. For the safety of you and those around you, read and follow these guidelines.

1. Always place the container on the ground and keep the nozzle in contact with the container when refueling to help prevent a static electricity ignition of fuel vapors.
2. Containers should never be filled in or on the back of a pickup truck or any other vehicle, or marine craft.
3. When filling, manually control the nozzle valve throughout the filling process. Fill the container slowly to decrease the chance of static electricity buildup and to minimize spilling or splattering.
4. **Never** smoke, light matches, use lighters, use cell phones or other electrical devices while filling.
5. Discharge your static electricity before fueling by physically touching a metal surface away from the nozzle.
6. Vapors can cause flash fires.
7. Vapors can be ignited explosively by a spark or flame many feet away.
8. Use and store in a well ventilated location.
9. **DO NOT** store indoors or in a vehicle.
10. **DO NOT** siphon gas by mouth.
11. If gas is swallowed, **DO NOT** induce vomiting, Call physician immediately.
12. Avoid repeated or prolonged contact with skin or breathing of gas vapors.
13. Keep out of reach of children.
14. Fill cap, dispensing valve and outlet valve must be closed tightly after each use.
15. **DO NOT** overfill container.
16. **If a fire starts, do not remove nozzle**—back away immediately.
17. Refer to posted warnings on dispensing pump.
18. Dispensing hose must be empty while transporting.
19. Secure container during transport. Never use bungee type rubber cords. They may not restrain the container. Chain or cable is recommended.
20. Never leave in direct sunlight or in the trunk of a vehicle.
21. If gasoline spills on the container, make sure that it has evaporated before using or transporting.
22. Regulations for the transportation of gasoline vary from state to state and even locally. Check all federal, state and local regulations.

WARNING AND INSTRUCTIONS FOR TRANSPORTING

The transportation of gasoline has certain inherent risks. Todd Enterprises has taken every precaution to provide you with the safest possible container for this purpose. However, to ensure safety during transport, the user must take the following precautions:

1. **When gasoline is transported in a commercial vehicle a Flammable Liquid sign must be displayed in clear view on the back of the vehicle.**
The sign should be removed from display when not transporting gasoline.
2. **Transport the Gas Caddy in the HORIZONTAL position ONLY!**
3. **The dispensing hose must be empty during transport.** One can empty the hose by : Tilting the tank to its horizontal position, opening the ball valve, lifting the hose above tank level and opening the nozzle valve to drain the fuel back into the tank, or into the container being filled.
4. **Vent cap must be attached securely and vent closed.**
5. **The Gas Caddy must be secured to the vehicle so that it cannot be moved.** This can best be accomplished by laying the Gas Caddy in the horizontal position and then running a chain or cable through the center hole of the Gas Caddy and securing the chain or cable to an immovable object on the vehicle. Secure the Gas Caddy so there is the minimum likelihood that loose objects in the vehicle do not puncture the Gas Caddy.
6. **Regulations for the transportation of gasoline vary from state to state and even locally.** The vehicle operator is responsible for compliance with all Federal, State and local transportation regulation. Contact your local DOT or police department for information.

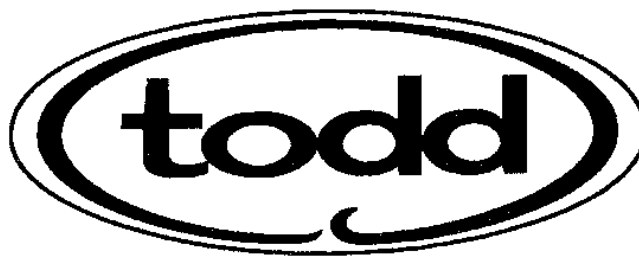

TODD Manufacturing
530 Wellington Ave.
Cranston, RI 02910

Corporate Office
361 Neptune Ave.
W. Babylon, NY 11704

Phone: 631-661-8300